

CABLE MANAGEMENT

Description

The horizontal cable management can be used with all patch panels, rack and cabinet mount products. It mounts on standard 19" racks or cabinets and provided a clean, beautiful and simple means of organizing from small to large bundles of cables and patch cord.

Features

- ▶ **Feature: Standard EIA 19" rack and Cabinet mount**
- ▶ **Management improves the look of a closet or workstation, it is an essential element For easy adds, moves or changes, it is also crucial to maintaining cable integrity by Ensuring resisted steel and ABS**
- ▶ **Light weight ,easy to install or removal**
- ▶ **The panel is configured with 24 rings**
- ▶ **Color: black anodized**
- ▶ **Custom-made cable management is acceptable**



CABLE MANAGEMENT

Product Figure

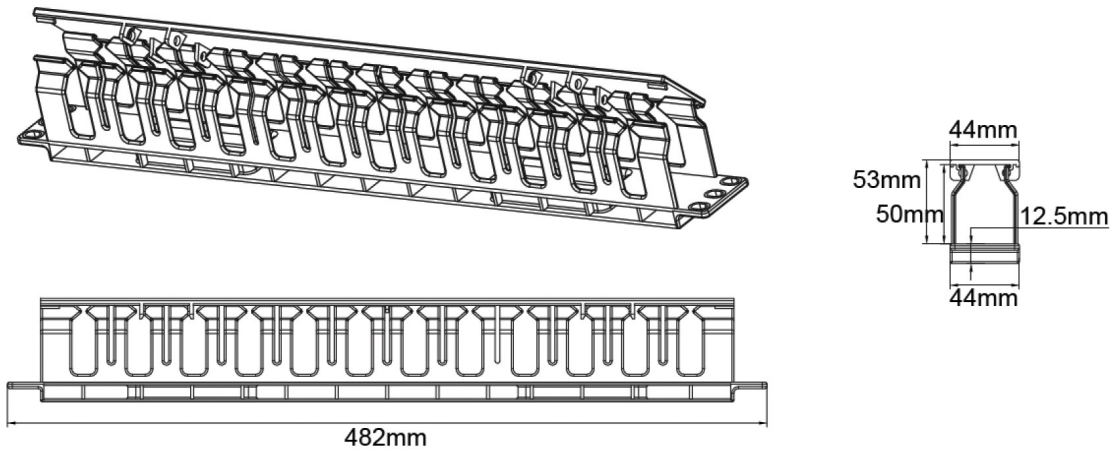

Order Information

Part No	Description	Standard Color	Inner box	Carton	Carton measurement	Carton weight
CS-RM1HCMP	cable management	Black	1PC	10PCS	L 53.6cm× W 31.3cm × H 24.6cm	4.80KG

COLOR

