

WDC WALL MOUNT DOUBLE SECTION NETWORK CABINET

Features and Benefits

- **Applications:**

WDC Wall mount double section network cabinet is a compact, secure enclosure widely used in structured cabling and networking projects because it balances space efficiency with easy accessibility. secure enclosure designed for housing networking equipment (like switches, patch panels, and routers)



- **Key Features:**

- **Surface finish:** Degreasing, pickling, phosphating, electrocoating, and powder coating with a thickness of 80µm–100µm. Compliant with RoHS standards.
- **Ventilation:** Vented top covers, fan mounting provisions for Some models feature vented glass or mesh doors to improve circulation.
- **Side Panels:** Lockable and removable side panels for easy installation and maintenance.
- **Cable Access:** Top/Bottom Cutout for cable entry/exit.
- **Cable Management:** Multifunctional cable management boards located on both sides of the rear Section.
- **Mounting:** Mounting rails with clearly marked U positions for precise equipment installation.
- **Cabinet Structure:** Efficient and robust cabinet connections for enhanced stability.
- **Grounding:** Optional provision of earthing kits for safety and compliance.
- **Security:** Lockable front, rear doors and side panels to keep equipment secure.
- **Load Capacity:** typically support load capacities ranging from 60 - 12KG depending on Cabinet U/Height size.
- **The double section:** feature means the cabinet has two parts: a front section (with a glass or metal door) and a rear section that can swing open, making installation and maintenance easier.
- **Standard:** Comply with ANSI/EIARS-310-D, DIN41491;PART1, IEC297-2, DIN41494;PART7, /T3047.2-92, ETSI and 19 inch international standard.



Physical Specification

- **Structure:**
Excuser Type: WDC Series Network Wall Cabinet /Enclosure
Mounting Type: Horizontal 19 inch front.
Material: Cold-rolled Steel
Frame Thickness: 1.5mm
Mounting Rail Thickness: 1.5mm
Side Panel Thickness: 1.2mm
Front & Back Doors Thickness: 1.2mm
Fix Shelf Thickness: 1.2mm
Color: Black (RAL9004)



WDC WALL MOUNT DOUBLE SECTION NETWORK CABINET

Structural Parts, Panel and Doors Options

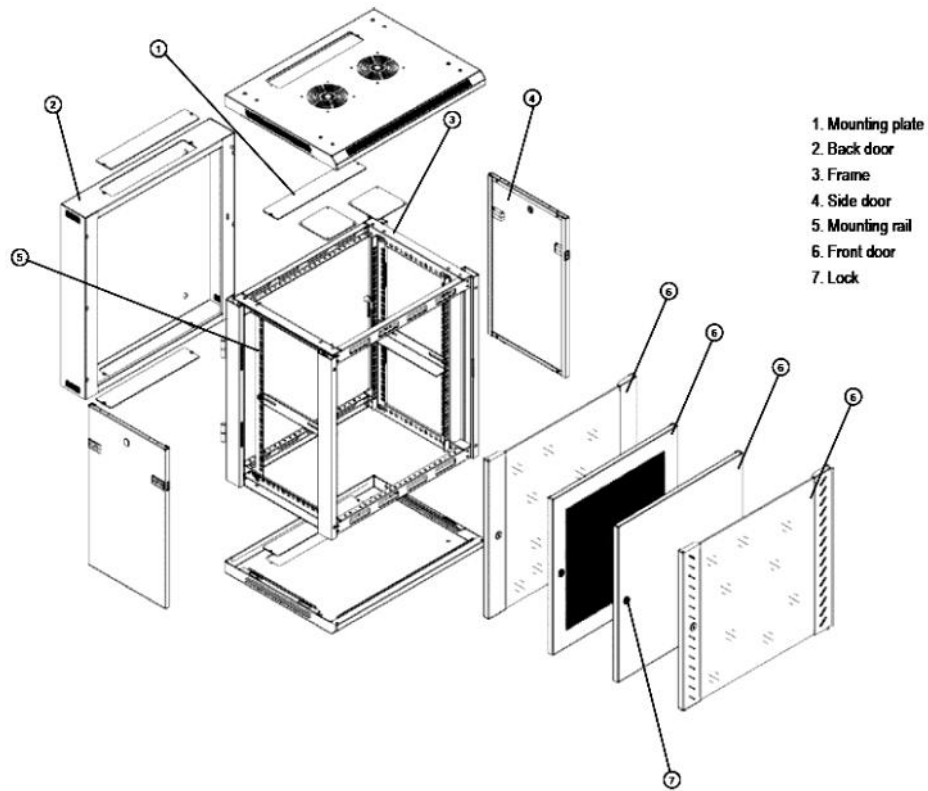

Standard Accessories & Specification

S/No	Specification	Qty	Material	Surface Finish
1	Frame	4	1.5mm cold rolled steel	Powder coated
2	Front door	1	1.2mm cold rolled steel	Powder coated
3	Side panel	2	1.2mm cold rolled steel	Powder coated
4	back door	2	1.5mm cold rolled steel	Powder coated
6	Lock	4	—	—
7	Mounting rail	4	2.0mm cold rolled steel	Powder coated
8	Fixed shelf	1	1.5mm cold rolled steel	Powder coated
9	Top cable inlet cap	1	1.5mm cold rolled steel	Powder coated
10	Bottom cable inlet cap	1	1.5mm cold rolled steel	Powder coated
11	Fans top mount	2	—	—
12	Power Plug (UK Type) for Fans	1	—	—



WDC WALL MOUNT DOUBLE SECTION NETWORK CABINET

Doors Options

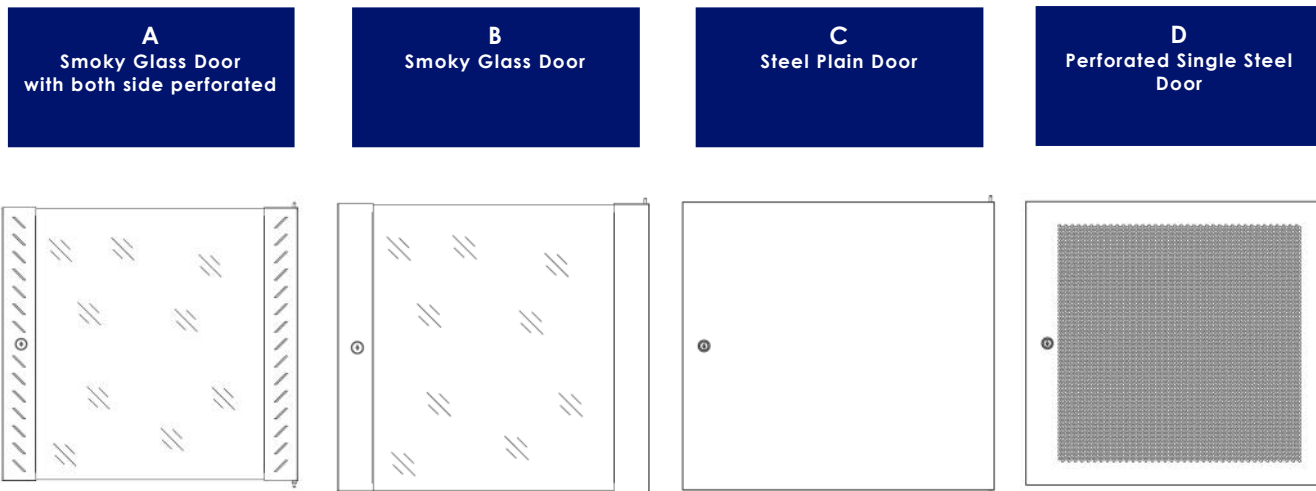

Ordering Information

Part Number	Capacity U	Width/mm	Depth/mm	Height/mm
CS-WDC-06-655-XXX	6U	600	550	350
CS-WDC-06-660-XXX	6U	600	600	350
CS-WDC-09-655-XXX	9U	600	550	500
CS-WDC-09-660-XXX	9U	600	600	500
CS-WDC-12-655-XXX	12U	600	550	640
CS-WDC-12-660-XXX	12U	600	600	640
CS-WDC-15-655-XXX	15U	600	550	800
CS-WDC-15-660-XXX	15U	600	600	800
CS-WDC-18-655-XXX	18U	600	550	1000
CS-WDC-18-660-XXX	18U	600	600	1000

Color Options

A—Black(RAL9004)



G—Gray(RAL7044)



Product Part Number Description:

